

REV	ZONE	DESCRIPTION	BY	DATE	CHK
A	N/A	RELEASE TO PRODUCTION	REBEALL	02-MAY-2024	33033

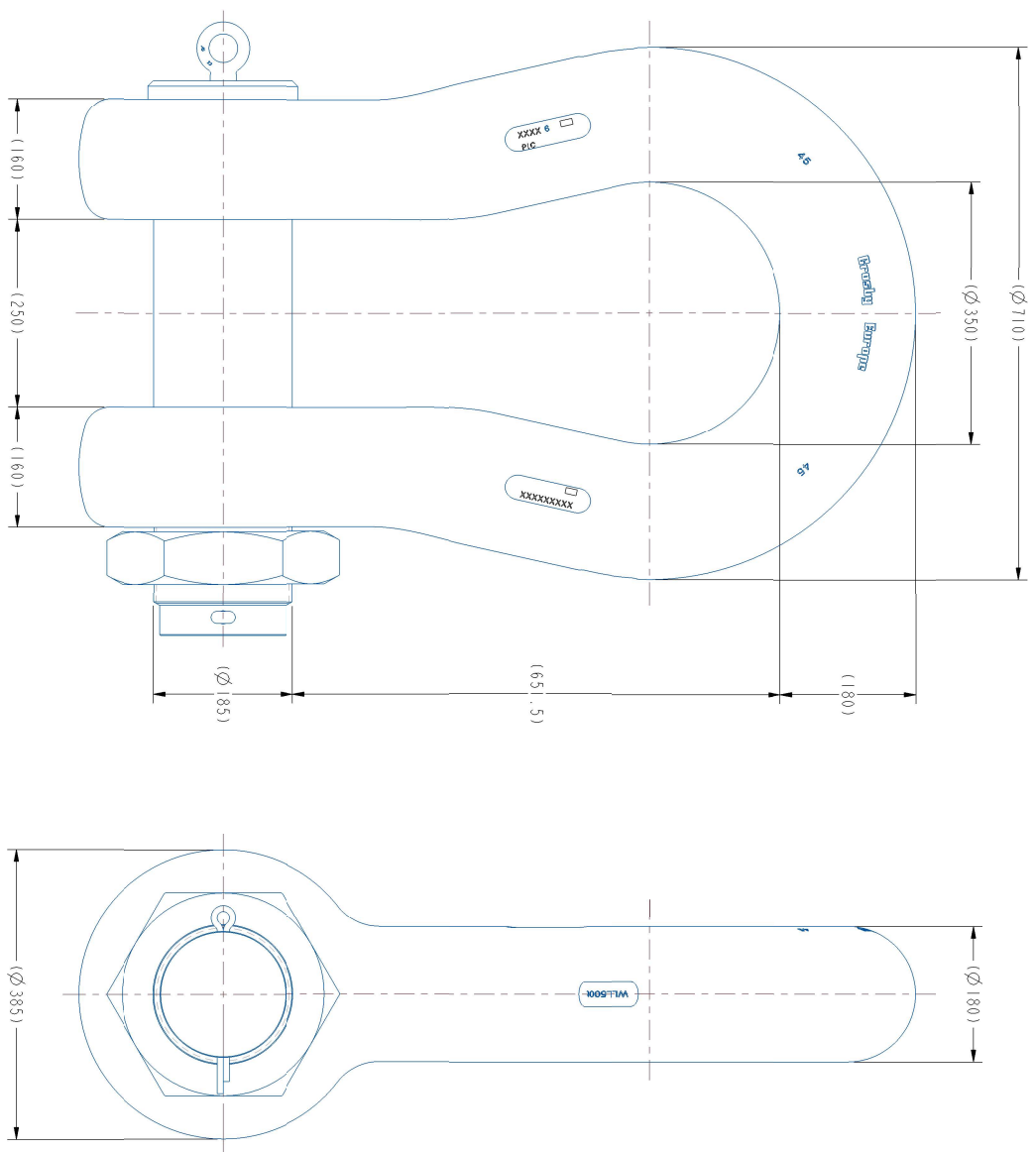

- NOTES:
1. WORKING LOAD LIMIT: 500 METRIC TONS AT 5:1 DESIGN FACTOR.
 2. INDIVIDUALLY PROOF TESTED TO 2X WLL
 3. MEETS PERFORMANCE REQUIREMENTS OF GRADE 8 SHACKLES
2. COATING:
- BOW: ALUMINIUM PAINT
 - BOLT: INORGANIC ZINC, PAINTED RED
 - NUT: PAINTED RED
 - COTTER: ZINC PLATED

UNLESS OTHERWISE SPECIFIED: ALL DIMENSIONS ARE IN millimeters. DIMENSIONS ARE BEFORE COATING. BREAK ALL SHARP EDGES. MACHINE SURFACES: $\nabla 1.25$		COATING: SEE NOTES		STATUSES: PRODUCTION		CORPORATE HEADQUARTERS 2800 NORTH CENTRAL EXPRESSWAY RICHARDSON, TX 75080 WWW.THESCOSBYGROUP.COM 1800/721800	
METRIC		MATERIAL: N/A		HEAT TREATMENT: N/A		DRAWN BY: REBEALL	
THIRD ANGLE PROJ.		HARDNESS: N/A		DATE: 02-MAY-2024		ENGINEER: JLEWIS	
DO NOT SCALE		REFERENCE: N/A		DISCLOSURE OF THIS DOCUMENT IS NOT PERMITTED UNLESS AUTHORIZATION IS EXPRESSLY GRANTED IN WRITING BY THE COSBY GROUP LLC		PRODUCT LINE: S2135	
INTERPRET DIMENSIONS AND TOLERANCES PER ASME Y14.5-2009		DISCLOSURE OF THIS DOCUMENT IS NOT PERMITTED UNLESS AUTHORIZATION IS EXPRESSLY GRANTED IN WRITING BY THE COSBY GROUP LLC		SUPERSEDES: N/A		SCALE: 1:5	
						DRAWING NO.: 1205234	
						PART NO.: 1205234	
						SHEET 1 OF 1	

4 3 2 1

A B C D

4 3 2 1

A B C D

FORMATT C SIZE